



Today's  
Bride<sup>®</sup>  
WEDDING SHOW

EXHIBITOR  
MANUAL

SATURDAY & SUNDAY,

**JANUARY**

**25 & 26** 2025

**I-X CENTER**  
ONE I-X CENTER DR.  
CLEVELAND, OH

**SATURDAY: 12 PM-6 PM**

**SUNDAY: 10 AM-4 PM**

**EXHIBITOR RESOURCES**  
[pros.TodaysBride.com/January](https://pros.TodaysBride.com/January)

# Today's Bride®

WEDDING SHOW

**January 25 & 26, 2025 • I-X Center**  
Saturday: 12 PM - 6 PM • Sunday: 10 AM - 4 PM

Show Day Exhibitor Help **Hotline**

**440-482-1055**

Need electricity? Trash overflowing?  
Music too loud? Call or text to report  
an issue without leaving your booth!

## We are pleased to present the Exhibitor Manual for the I-X Center Show on January 25 & 26, 2025.

Inside this manual, you'll have a record of important deadline dates, general guidelines, exhibitor rules, important exhibitor documents, and added-value promotional opportunities.

This entire manual, online forms, and additional helpful resources to prepare you for the show are available online at:

### [Pros.TodaysBride.com/January](https://pros.TodaysBride.com/January)

Please take the time to review the manual and website in their entirety, and share the information with your staff who will be setting up and/or working the show.

Thank you for being a part of the January Show! We are here to assist in any way we can before, during, and after the show. Don't hesitate to ask for our input on booth design ideas, marketing techniques, and more.

**330-670-9545**  
or **216-393-5677**

**Jennifer Judy** x14  
jennifer@todaysbride.com

**Jim Frericks** x16  
jim@todaysbride.com

**Abby Frericks Crowder** x12  
abby@todaysbride.com

**Kelsey O'Hearne Bohl** x22  
kelsey@todaysbride.com

**Phil Bell** x23  
phil@todaysbride.com

## DEADLINES

### SUNDAY, DECEMBER 15, 2024

Final Show Balance Due

### FRIDAY, DECEMBER 20, 2024

Pink Stuff-It Bag Program Materials Due

Deliver or ship 2,000 flat pieces to the Today's Bride Office

**NEW ADDRESS:** 3550 Ridgewood Rd., Fairlawn, OH 44333

**Learn More:** [pros.TodaysBride.com/jan-add](https://pros.TodaysBride.com/jan-add)

### MONDAY, JANUARY 6, 2025

Last Day to Order Electric at Discounted Rate

(if not included in your booth package)

**To Order:** [ordering.edlen.com](https://ordering.edlen.com)

### FRIDAY, JANUARY 10, 2025

Return Credentials Form

**Learn More:** [pros.TodaysBride.com/jan-cred](https://pros.TodaysBride.com/jan-cred)

### FRIDAY, JANUARY 10, 2025

Reserve Fashion Show Stage Commercial and Big Screen Video Space

## GUIDED TOUR OF I-X CENTER

WEDNESDAY, DECEMBER 11, 2024 | 1:00-2:00PM

RSVP if attending to [jennifer@todaysbride.com](mailto:jennifer@todaysbride.com)

### WEDNESDAY, JANUARY 15, 2025

Order Additional Booth Rental Items

Call Angel at Miller's Party Rental at 330-753-9104 or email

[amk@millersparty.com](mailto:amk@millersparty.com) to reserve. Rental fees apply.

**Learn More:** [pros.TodaysBride.com/jan-add](https://pros.TodaysBride.com/jan-add)

### WEDNESDAY, JANUARY 15, 2025

Reserve Space and Rentals for the Inspiration

Galleries (Tables, Gowns, Cakes, Photos)

To reserve space: Contact Abby at 330-670-9545 x12

or email [abby@todaysbride.com](mailto:abby@todaysbride.com)

To reserve rentals: Contact Lasting Impressions Event Rentals at 216-591-1177 or email [veronica@lirents.net](mailto:veronica@lirents.net)

### FRIDAY, JANUARY 17, 2025

Pre-order parking passes from I-X Center for \$10/day (versus \$12/day after January 17, 2025)

**To Order:** [pros.todaysbride.com/ix-orderform](https://pros.todaysbride.com/ix-orderform)



<b>SHOW DAYS</b>	<b>Saturday, January 25</b> Fashion Shows	<b>12 PM – 6 PM</b> 1:30 PM, 3:00 PM & 4:30 PM	Silent Opening: 11:30 AM, be ready!
	Happy Hour	6 PM - 7 PM	Networking Event at the I-X Yuengling Pavilion Bar. Two complimentary drink tickets per company will be in your Exhibitor Packets at check-in.
	<b>Sunday, January 26</b> Fashion Shows	<b>10 AM – 4 PM</b> 12:30 PM, 1:30 PM & 2:30 PM	Silent Opening: 9:45 AM, be ready!

<b>MOVE-IN</b>	<b>Friday, January 24</b>	<b>9 AM – 4:30 PM</b>	Free Parking. Drive-in Passes permitted. (\$35 for one-way pass, \$50 for round trip pass)
	<p>On Friday only, you may use a paid drive-in pass purchased from the I-X Center, which permits you to drive into the facility to unload. Drive-in passes are valid for up to one hour to drive in, unload your vehicle, and remove your vehicle. Some vehicles may not be able to unload close to their booth, depending on vehicle clearance on the show floor. Drive-in passes are available for any type of car, van, truck, or trailer without additional labor required. Visit <a href="https://pros.todaysbride.com/ix-orderform">pros.todaysbride.com/ix-orderform</a> to pre-pay for a drive-in pass, or purchase the pass on Friday during move-in at the I-X Center Customer Service window from 9:00 AM - 3:30 PM.</p>		
	<b>Saturday, January 25</b>	<b>8 AM – 11 AM</b>	Paid parking: \$12 per vehicle all day. No drive-ins; Hand-carry or use dollies only.
	<b>Sunday, January 26</b>	<b>9 AM - 9:45 AM</b>	Paid parking: \$12 per vehicle all day. No drive-ins; Hand-carry or use dollies only.

**IMPORTANT! UNLOADING is NOT permitted through the main EAST ENTRANCE Lobby Doors.**

**YOU MAY USE YOUR OWN 2 OR 4-WHEEL DOLLY/CART TO UNLOAD/LOAD YOUR VEHICLE without purchasing labor.** If you need labor assistance to UNLOAD/LOAD, schedule with Miller's Party Rental at 330-753-9104 or email [amk@millersparty.com](mailto:amk@millersparty.com).

**MOVE-OUT Sunday, January 26 4 PM – 7 PM**

**No exhibits may be taken down until after 4 PM.**

Drive-in pass vehicles may start entering the building at approximately 5:00 PM.

Vehicles cannot drive onto the show floor until the limousines have exited & most of the foot traffic has left.

The takedown, removal, or repackaging of booth materials and/or displays during posted show hours is strictly prohibited. Not only is this disrespectful to attendees and neighboring booths, but it poses a hazard while transporting materials through the event facility. Early tear down will result in forfeiture of the lead list and a \$100 fine.

**EXHIBITOR ENTRANCE** Located at Door 35A. (See map)  
Look for the Exhibitor Entrance awning.

**CHECK-IN** Today's Bride will have a CHECK-IN Booth during move-in at Door 35A to pick up your Exhibitor Packets and credentials during move-in hours.

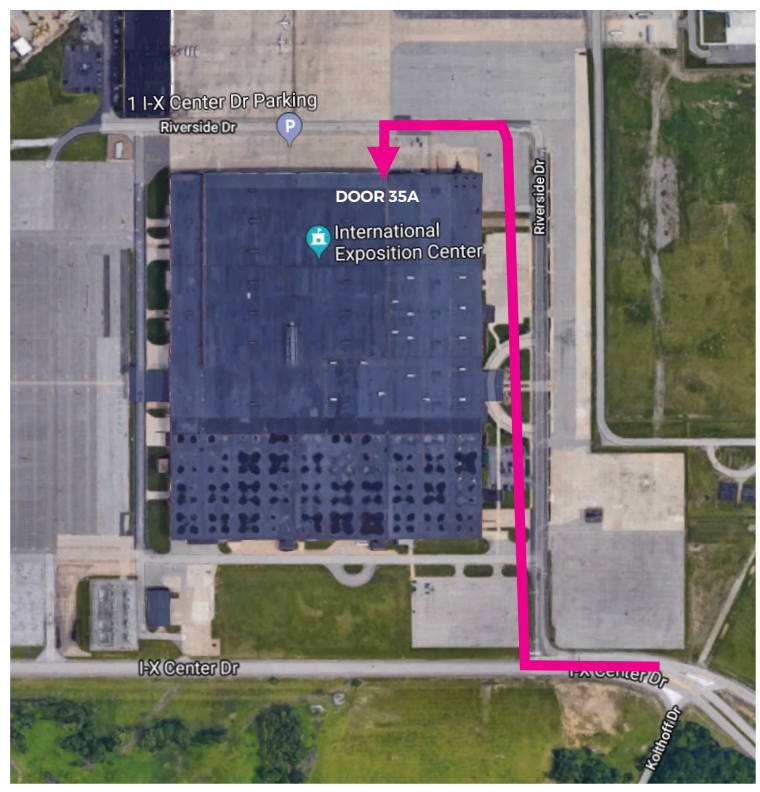

# Today's Bride®

## WEDDING SHOW

January 25 & 26, 2025 • I-X Center

Saturday: 12 PM - 6 PM • Sunday: 10 AM - 4 PM

Show Day Exhibitor Help **Hotline**

**440-482-1055**

Need electricity? Trash overflowing?  
Music too loud? Call or text to report  
an issue without leaving your booth!

### OHIO TRANSIENT TAX LICENSE

Retailers selling at the show are responsible for complying with all vendor-licensing requirements. For additional information or to apply for an Ohio Transient Vendor's License, call 888-405-4089 or visit [tax.ohio.gov](http://tax.ohio.gov).

### FOOD SAMPLE GUIDELINES

Selling food products is not permitted. All sampling requests must be submitted at least 10 days before the show. Sampling is limited to a 2-oz. portion for food and a 4-oz. portion for beverages. The items being sampled must be part of your business services. No samples of any alcoholic beverages are permitted. Submit the following Sample Authorization Request form found online with the URL link below.

(URL: <https://todaysbride.com/wp-content/uploads/2024/03/I-XCenter-Food-Sample-approval-Form.pdf>)

### DELIVERIES

Deliveries from common carriers (UPS, FedEx, 3rd parties, etc.) will incur drayage charges for receipt of their delivery, storage, delivery to booth, and return to docks to send out after the event. Call Miller's Party Rental Center at 330-753-9104 to discuss arrangements and fees ahead of time.

### CLEAN-UP

Each evening after set-up and when the show closes, you can put trash in the aisles, and the I-X Center staff will dispose of it. Please bring your own trash bags.

### IDENTIFYING ATTENDEES

For easier identification, engaged attendees will be wearing a pink "I Said Yes!" Today's Bride sticker.



### LUNCH OPTIONS

Outside food or drink is not permitted to be brought into the I-X Center. Concession areas will be available throughout the show with ample seating.

### WI-FI SERVICE

I-X Center offers internet service for a fee through Smart City Networks. They do not accept pre-orders. Order during move-in or on the day of the show by opening the Wi-Fi settings on your device and selecting "Exhibitor Internet." Visit the URL link for pricing.

(URL: [https://pros.todaysbride.com/wp-content/uploads/2023/11/I-XCenter\\_WIFI.pdf](https://pros.todaysbride.com/wp-content/uploads/2023/11/I-XCenter_WIFI.pdf))

### ELECTRIC

If an exhibitor wants electric above what is included (or excluded) from your contract, you must order from Edlen directly at <https://ordering.edlen.com>. Order by Monday, January 6, 2025, to receive discounted rates.



# ON-SITE WIRELESS SERVICES

## I-X CENTER LOCAL EXHIBITOR

### NEED WIRELESS CONNECTIVITY?

Smart City Networks offers on-site wireless services for both attendees and exhibitors. Our **Complimentary Internet** is offered free of charge in the concession area. Our **Exhibitor Internet** is available facility-wide on a 5 GHz wireless network, at speeds of 3 Mbps up/down per device. Depending on where you are in the facility, you may see both SSIDs (network names), but only Exhibitor Internet is supported in all areas.

#### EXHIBITOR INTERNET

Exhibitor Internet is available throughout the facility. Each purchase is device specific.

**1 day for \$49.95**  
**3 days for \$149.85**  
**5 days for \$249.75**

#### HOW TO CONNECT TO EXHIBITOR INTERNET

1. Open Wi-Fi settings on your device and select "Exhibitor Internet".
2. First time users will be asked to create an account and select a purchase option.
3. Follow the on-screen instructions to get connected.

#### COMPLIMENTARY INTERNET

Complimentary Internet is a free service and is available for use in all public spaces and meeting rooms.

#### HOW TO CONNECT TO COMPLIMENTARY INTERNET

1. Open Wi-Fi settings on your device and select "Free Internet".
2. First time users will be asked to create an account and verify their email address to get connected.

For questions regarding on-site wireless services, please call Smart City Networks at 216-265-7104. To order any other services we provide, please visit us online at: [orders.smartcitynetworks.com](http://orders.smartcitynetworks.com).



# BOOTH REGULATIONS

## INCLUDED WITH SINGLE FURNISHED BOOTHS & LARGER:

- 8' high BLACK back pipe & drape
- 3' high side rails to separate your booth from neighbors
- 6' rectangle table covered in standard BLACK linen
- 2 chairs, if needed
- Company Name Placement Sign
- Nametags for Staff

\*Tabletop booths include a covered 4' table with black linen and 1 chair.

\*Naked unfurnished booths do not include a covered table or chairs.

Below are the booth design regulation guidelines. For a SINGLE BOOTH, plan within a 9' x 9' area due to vertical poles & bases taking up an extra foot.

1. Displays taller than 8' must get approval from Today's Bride 30 days prior to the show. The backdrop must be tastefully finished on the back side.
2. Pipes or trusses placed at the front of the booth space are acceptable provided the sides of the space do not obstruct the neighboring booth and there is a clear line of sight from both sides.
  - Don't position retractable banners at the front of your booth space. Move halfway back or towards the back.
  - The front 5' of your exhibit may not exceed 4' in height, unless it's a see-through structure.
  - Property or displays taller than 4' must be placed into the rear half of the exhibit space.
3. Stay within the space confines of your booth. Exhibitors are prohibited from standing in the aisles or having their booth displays extend into the aisles.
4. If you plan to uplight your booth backdrop, you must bring or rent your own pipe & drape backdrop to place in front of the drape that is shared with the exhibitor behind you. The light will show through the thin drape.

If you are concerned your exhibit is not within the above guidelines, contact the Today's Bride team at: 330-670-9545 or email [shows@todaysbride.com](mailto:shows@todaysbride.com). If your exhibit isn't within the guidelines, you may be asked to make changes during move-in.

Exterior of any part of display facing a booth must be finished or suitably decorated.

Signage may not read into neighboring booths.

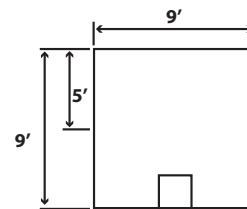
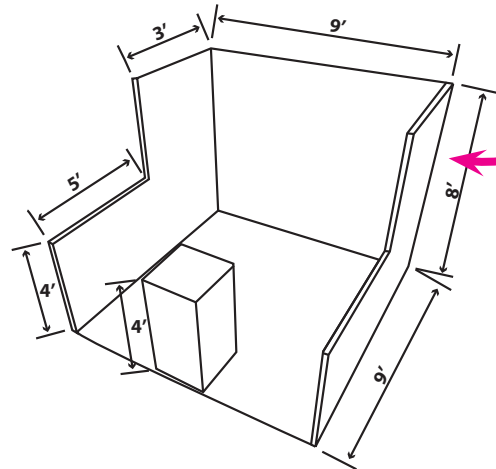

Overhead

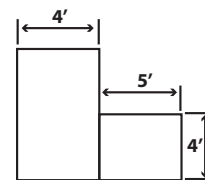

Left Side

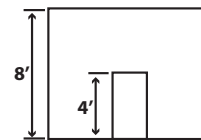

Front

# THE RULES & REGULATIONS

**NOTE: It is your responsibility to understand and abide by these rules.**

Our insurance carrier and facilities instructed us to strictly enforce the show rules and regulations as indicated on your show contract. This will ensure a safe and enjoyable trade show experience not only for participating businesses but, more importantly, our valued attendees. Please read and adjust your presentation and set-up display if necessary.

**Review and share these guidelines with your staff scheduled to work your booth prior to the event.**

1) Booth staff and all display materials **must stay within their contracted booth space** and not infringe upon the aisle walkways or other booth spaces. All aisles must remain clear of obstruction. Maximum backdrop height is 8' tall. The front 5' of your booth may not exceed 4' in height unless the structure is see-through. Backdrops taller must get approval from Today's Bride. Some booth locations are restricted.

2) **Maximum of four staff members** are permitted to exhibit in a single booth space at one time. **Maximum of two staff members** permitted at one time in a Table Top Space.

3) **NO distribution** of any marketing materials is permitted in the event facility, outside of contracted booth space. This includes, but is not limited to: exhibit hall aisles, registration areas, seating areas, rest rooms, parking lot/garage or other event facility grounds.

4) No helium balloons are allowed in the facilities.

5) **Candles, votives or any item creating an open flame are not permitted inside the I-X Center unless as an approved activity or exhibit.** All activities and/or exhibits with open flames require a minimum of seventy-two (72) hour advance notice, prior to the first Event date, for review and written approval from the Event Manager and Cleveland Fire Marshal (if applicable).

6) **Distribution of any non-participating, non-contracted business literature (business cards, brochures, signage, etc.) is strictly prohibited.** This includes, but is not limited to, photographs or displays with "courtesy of" acknowledgment of said businesses. The only exception is if the mentioned business is also an exhibitor at the current show.

7) Distributing literature or displaying signage regarding a **competing Bridal Show or Event** (whether at your facility or not) **is strictly prohibited** unless Today's Bride is a sponsor of the event.

8) **Exhibitors MAY NOT begin to take down their booth display prior to show close.** The take down, removal, or repackaging of booth materials and/or displays during posted bridal show hours is strictly prohibited. Any set-up and disassembly must take place prior to guests' arrival and after their exit. You will be held accountable for any injury that may occur as a result of your negligence, forfeit the show's lead list, risk approval to exhibit at future Today's Bride Shows, and be fined \$100. Additionally, guests pay admission for a show advertised with set hours of availability, and we must honor these hours.

9) **All food and liquids to be served as samples** must be approved by both the facility and Jadlyn Inc./Today's Bride at least two weeks before the show. Distribution of samples without prior approval is not permitted and may result in dismissal of exhibit space at the show. Sample sizes are restricted to 2oz or less for food, 3oz or less for liquids. Alcohol is strictly prohibited. Open flame warmers or

cooking equipment is not permitted (including Sternos). Submit the following Food Sample Authorization Form at least 10 days before the show to request approval: <https://todaysbride.com/wp-content/uploads/2024/03/IXCenter-Food-Sample-approval-Form.pdf>

10) **Any outside food or drink for staff consumption is not permitted to be brought into the event facility.** Concession areas are available to purchase snacks and food during meal times.

11) **Distribution of alcoholic beverages, in any form, to attendees is strictly prohibited.**

12) **All audio, video and/or gaming productions must be maintained at appropriate noise levels** so not to infringe on the peace and harmony of neighboring booths. Jadlyn Inc./Today's Bride reserves the right to determine and set the acceptable sound level. Exhibitor is responsible for compliance of all music licensing.

13) Your company/businesses **must provide its own surge-suppressant power strip and extension cord(s)** to use for your trade booth's electrical needs.

14) **The leads generated from this show are for the exclusive use of the exhibitors who made the investment to participate.** The lead lists are seeded. Today's Bride monitors what you are sending. It is a violation of your exhibitor agreement to sell, lend, reproduce, exchange, copy or share the lead list to any non-exhibiting business or non-sponsored show or event that isn't authorized for this list. If this information is used or threatened to be used in an unauthorized manner, Today's Bride shall be entitled to seek relief in any court of competent jurisdiction, including but not limited to injunctive relief, actual and punitive damages, reasonable attorney's fees, costs and any and all other expenses. It is also a violation to use the list or permit the list to be used to promote any other multi-business bridal- or wedding-related show or event, including Client's own participation within such an event, and that damages to Today's Bride for each such use shall be no less than \$3,000.00. (A "use" shall mean each letter, mailing or e-mail sent to an attendee on the lead list). Upon breach of this Contract for any reason, exhibitor's license to use such Lead List shall cease immediately.

15) **Exhibitor shall make good any damage to the building or fixtures caused by exhibitor or any of exhibitors' agents or employees.** Exhibitors are responsible for any loss of their equipment and/or display material, or personal belongings, resulting from accidental breakage, misplacement, theft, fire or natural disaster, including, but not limited to, damage occurring while Management staff is assisting an exhibitor. If exhibitor uses the services of Management staff, then exhibitor agrees that the staff member is a volunteer for the exhibitor for worker's compensation purposes.

16) **The Exhibitor is responsible for insuring its exhibit, personnel, display, automobiles, trailers, and materials against any damage or loss resulting from theft, fire, accidents, or any other cause.** The Exhibitor acknowledges and assumes all risks associated with the use of the exhibit space and its surroundings. The Exhibitor agrees not to make any claims, demands, or legal actions against Today's Bride/Jadlyn, Inc, the Show sponsors, or the facility hosting the Show for any loss, damage, or injury incurred by the Exhibitor, its officers, directors, agents, representatives, employees, or their respective property. Nei-

**These and all existing regulations will be strictly enforced. Violation to regulations may result in the exclusion from future trade shows and/or forfeiture of trade show lead list.**





## PRE-SHOW PREP

### 12 weeks before the show:

- Download the Exhibitor Manual to prepare and track deadlines [pros.TodaysBride.com/January](http://pros.TodaysBride.com/January)
- Set Goals for the Show
  - Number of appointments
  - Testing a new product
  - Taking deposits
  - Signing contracts
- Plan your booth design
  - Layout • Decor • Flooring
  - Banners • Signage • Electric Access
- Order marketing materials: flyers, promo items, samples, show special to offer, literature for brides Pink "Stuff-It" Bags (if contracted)

### 6-4 weeks before the show:

- Stuff-it Bag Materials delivered to Today's Bride by **December 20, 2024**  
Please note, we have recently moved to a new office! Our new address is **3550 Ridgewood Road, Fairlawn, OH 44333**.
- Order any extra rentals from a decorator, rental company, or venue
- Prepare a way to collect hot leads at the show (guest book, paper, or electronic forms)
- Pre-promote your presence at the show: share on social media, website, emails, voicemail & more
- Post online banner images promoting your booth and/or show special. Banners are located on the Exhibitor Manual website: [pros.TodaysBride.com/January](http://pros.TodaysBride.com/January)

### 3 weeks before the show:

- Proof your online listing on [TodaysBride.com](http://TodaysBride.com)
- Audit your design & branding on your website and social media

### 2 weeks before the show:

- Submit your Sign & Nametag Credentials Form by **January 10, 2025**
- Submit your Show Special to post on [TodaysBride.com](http://TodaysBride.com)
- Create a packing list of what to bring to the show (see right)
- Schedule & train your staff on booth etiquette, rules, the sales process, and show specials
- Plan parking and lunch options for your staff
- Prepare lead collection forms and the follow-up process (timing of phone calls, emails, direct mail, show special deadlines)
- Review the Exhibitor List online to strategize your networking

## POST-SHOW PREP

### After the show:

- Follow up on your hot leads from the show immediately
- Download the registered attendee list once alerted that it's available
- Continue working the leads throughout the attendees' engagement
- Renew the next show date to keep your online listing active

## PACKING LIST

- ♥ Electrical Cords & Surge Protector
- ♥ Mobile Device Chargers
- ♥ Sales Literature
- ♥ Business Cards
- ♥ Appointment Book
- ♥ Clipboards
- ♥ Booth Design Layout
- ♥ Dolly or Transporting Devices (Suitcase or Wagon)
- ♥ Masking Tape, Scotch Tape, Shipping Tape
- ♥ Scissors, Stapler, Safety Pins, Straight Pins
- ♥ Portable Vacuum/Steamer
- ♥ Pens, Sharpie Marker
- ♥ Trash Bags
- ♥ Aspirin, Band-Aids, Second Pair of Shoes
- ♥ Hand Sanitizer
- ♥ Lead Collection Forms (or laptop/tablet)
- ♥ Breath Mints
- ♥ Good Selling Plan & Attitude





# ATTRACT COUPLES TO YUR BOOTH WITH A SHOW SPECIAL

Show specials are a win-win for both couples & exhibitors at wedding shows! Attendees benefit by scoring deals and saving money, while exhibitors benefit by attracting more attention to their booth. Increase your chance of standing out, generating interest, and getting more leads by offering a limited-time show special.

## NEED INSPIRATION?

### DO YOU WANT SIGNED CONTRACTS?

- ♥ Book today for 10% off
- ♥ Sign this week to save \$100
- ♥ Book this week for only \$1,200
- ♥ Receive a free photo album when you book at the show

### DO YOU WANT MORE BOOTH VISITORS?

- ♥ Spin the wheel for an instant gift
- ♥ Play Plinko for a discount
- ♥ Listen to our demo for a free koozie
- ♥ Stop by our booth for a free catering or cake sample

### DO YOU WANT TO COLLECT MORE LEADS?

- ♥ Enter to win \$500 off any package
- ♥ Enter to win a free overnight stay
- ♥ Schedule an appointment to get \$75 off your gown
- ♥ Enter to win \$200 with any purchase

Let us know about your show promotion and we'll help get the word out by:

- Posting it on the show page on [TodaysBride.com](http://TodaysBride.com).
- Several will be mentioned in an email blast promoting the show and shared on social media

**EMAIL YOUR SPECIALS TO  
[ABBY@TODAYSBRIDE.COM](mailto:ABBY@TODAYSBRIDE.COM)**

or submit it with your credentials form at  
[pros.todaysbride.com/jan-cred](http://pros.todaysbride.com/jan-cred)

## PROMOTE YOUR SPECIAL ON SOCIAL MEDIA

Follow us on:



**TAG us @todaysbride**  
so we can reshare!

# MARKETING UPGRADES

**PINK STUFF-IT BAG PROGRAM \$475\*** DEADLINE DECEMBER 20, 2024



Guarantee every couple goes home with your marketing literature, whether you talked to them or not, by having your literature pre-stuffed in every pink welcome bag. All you need to do is supply us with **2,000 flyers** by **December 20, 2024**.

**Ship or drop flyers off at:**  
Today's Bride, 3550 Ridgewood Road Fairlawn, Ohio 44333

- Payment must accompany flyers. • Limited availability for some categories (call for details).
- The flyers **CANNOT** contain names or phone numbers of non-show participating exhibitors.
- The flyers **CANNOT** advertise another bridal show (at your facility or elsewhere).
- The flyers **CANNOT** exceed 10 pages. No magazines allowed.
- All flyers must be a single piece item and FLAT (call for approval of anything else).

\*must be an exhibitor to qualify for this discounted price.

**FASHION SHOW STAGE COMMERCIAL \$100/ad** DEADLINE JANUARY 10, 2025

Promote your company's services to a captive audience awaiting our high-energy fashion shows! 10-second static ads will rotate throughout the day on the big-screen situated next to the fashion show stage.

**BIG SCREEN VIDEO \$100/video** DEADLINE JANUARY 10, 2025

Market to attendees by displaying your company's wedding video(s)! The big-screen situated next to the fashion show stage will rotate videos throughout show hours.



## WEBSITE

TodaysBride.com is averaging 16,000+ visitors a month. Traffic increases 30% more before & after the shows.

**BUY TICKETS ONLINE**  
Get 1 FREE TONIGHT! You may have your ticket confirmation email sent to you by clicking the following link.

**PARKING:**  
Parking is FREE in all city parking lots around the John S. Knight Center.

**ACTIVITIES**  
**INSPIRATION GALLERY**  
Get up close to the latest inspiration from our participating exhibitors. We will have a variety of the newest bridal gowns, reception tables and decor ideas, cakes, flowers and some favorite photos from photographers so you can compare their different styles and get ideas!

**WHAT YOU GET**  
Freebies for all registered Brides!  
✓ All Brides Get a FREE Tote Bag - a \$15.00 value!  
✓ FREE Issue of the BRAND NEW 2025

**VENDOR WEBSITE LINK**  
All exhibitors will receive a basic profile page. Add a link to your website for **\$100**

**FEATURED EXHIBITOR AD**  
**\$150** Rotating banner ad linked to your profile page.

**Today's Bride**  
Your Northeast Ohio Wedding Resource

FIND A LOCAL VENDOR Select Vendor Category

**RECEPTION VENUES - AKRON/CANTON**

**THE MANE BARN AT NICKAJACK FARMS**  
2955 Manchester Ave., NW, North Lawrence, OH 44666  
Website 330-323-9714

**OTHER RECEPTION VENUES - AKRON/CANTON VENDORS**

SpringLake Party Center  
1020 Main St., Lakewood, OH 44120 \$5

The Tanager  
132 W. Market St., Lakewood, OH 44120 \$55

To purchase marketing upgrade, visit [pros.TodaysBride.com/jan-add](https://pros.TodaysBride.com/jan-add)



# BOOTH DESIGN AWARD



January 2024: CAKE DRAMA



January 2024: BEYOND ESTHETICS

Go “all out” designing your booth and be rewarded with a Booth Design Award!

Your booth will be judged for Best Booth Design based on the following:

- ♥ Visual Display
- ♥ Creativity
- ♥ Functionality
- ♥ Staffing
- ♥ Best Use of Space
- ♥ Improvement from Year to Year

#### Need additional booth items to improve your display?

Miller's Party Rental Center is the official decorator for the Today's Bride Wedding Show. They are offering discounted pricing on various rental items. Any items ordered will be placed in your booth space before the show unless you prefer to pick them up at their warehouse. Call 330-753-9104 with any questions and to place your order.

**Deadline to order is January 15, 2025. Contact Angel at 330-745-9104 or amk@millersparty.com**

## DESIGN TIPS:

- 1. Most Important: Make sure your company name is prominent.** High and legible from a distance.
- 2. Consider adding lights to spotlight your products.** Exhibit halls have dim, indirect lighting. Lights will make a huge impact visually & your booth will stand out from a row of exhibits. (Bring your own extension cords and power strips!) Note: Please refer to our booth regulations regarding lighting on page 6.
- 3. Ditch the chairs and stand during the show.** Always appear interested and ready to assist potential customers.
- 4. Think UP!** Consider using vertical space in your booth. Invest in tall backdrops and banners up to 8' tall. Layer displays on a table. Rent high cocktail tables. Use barstools for your guests. You'll gain valuable square footage this way and the booth will be more appealing and functional.
- 5. Rent a unique backdrop.**

# SPREAD THE WORD CONTEST

Promote the wedding show to your followers for a chance to win one of these three prizes:

## FIRST PLACE



**Win a Booth**  
at the June 8,  
2025 I-X Center  
Wedding Show  
(\$1,300 value)

## SECOND PLACE



**Win a Local Love Ad**  
Or credit towards a  
larger ad in the 2026  
Today's Bride  
Magazine (\$625 value)

## THIRD PLACE



**Win an Email Blast**  
Sent by Today's  
Bride to 5,000+  
brides (\$600 value)

**THE MORE YOU PROMOTE THE SHOW,  
THE BETTER CHANCE OF WINNING!**

<b>1 ENTRY</b>	<b>FOR EVERY SOCIAL MEDIA POST TO YOUR BUSINESS PAGE</b> Post or share about being at the Today's Bride Wedding Show on your business social media accounts and tag @todaysbride to get points. A maximum of 3 points will be given for posts on the show day.
<b>3 ENTRIES</b>	<b>FOR EACH BLOG POST THAT MENTIONS THE SHOW</b> Send a link to points@TodaysBride.com.
<b>3 ENTRIES</b>	<b>FOR MENTIONING THE SHOW IN YOUR EMAIL SIGNATURE OR VOICEMAIL</b> Send an email to points@TodaysBride.com to let us know.
<b>5 ENTRIES</b>	<b>FOR MENTIONING THE SHOW IN AN EMAIL BLAST</b> Send an email blast to your prospect database inviting them to come and see you at the Today's Bride Wedding Show, and to contact you for free tickets. Add points@TodaysBride.com to your email list to receive credit.
<b>10 ENTRIES</b>	<b>FOR ADDING THE "TODAY'S BRIDE PARTNER" BADGE &amp; LINK TO YOUR WEBSITE.</b> Download the 2025 badge at <a href="https://pros.todaysbride.com/badge">pros.todaysbride.com/badge</a> and send a link to points@todaysbride.com.
<b>15 ENTRIES</b>	<b>FOR MENTIONING THE SHOW IN ANY OTHER TRADITIONAL ADVERTISING</b> (radio, TV, direct mail, print, etc.) Send an email to points@TodaysBride.com to let us know.

Each entry increases your chance of winning! Contest ends January 26, 2025, at 4:00 PM. Submit multiple entries for higher odds of winning!

Follow us on:      and tag us @todaysbride

(You must tag us to receive credit!)

\*Must be on an official business account

Hashtag **#TodaysBride** to start a trend!

visit **Pros.TodaysBride.com/promote**

for more banners, logos, and examples of how to create a post and how to tag us.



# GALLERY OF TABLES

With your expertise, couples can imagine their dream reception decor including table shapes, linens, centerpieces, chairs, china, and favors.

**ATTENDEES VOTE ON THEIR FAVORITE DESIGN!**  
Voting is controlled by only one vote per attendee.

## RESERVE YOUR SPACE TODAY!

SPACE IS RESERVED ON A  
FIRST-COME, FIRST-SERVED BASIS

DEADLINE TO RESERVE: JANUARY 15, 2025

### WHAT YOU NEED TO DO:

1. **Reserve your space:** Contact Abby Crowder at [Abby@TodaysBride.com](mailto:Abby@TodaysBride.com) or 330-670-9545 x12.
2. **For your table:** It's a 10' x 10' space. You are responsible for bringing everything.

-OR-

Borrow items at **no extra cost\*** from the gallery sponsor, Lasting Impressions Event Rental. They offer tables, chairs, linens, flatware and more! Contact Veronica to place your order: 216-591-1177 or [veronica@lirents.net](mailto:veronica@lirents.net)

Deadline to order is **January 15, 2025**



We encourage collaboration with other exhibitors and will list them on the table sign created by Today's Bride. Any contributing companies must be exhibitors in the show to receive credit. Non-exhibitors may contribute, but their company is not permitted to be promoted on the table or in your exhibit space.

These spaces are for inspiration only. No promotional materials or literature (this includes business cards and signs) will be allowed in the gallery.

Gallery is open to venues, florists, planners, rental companies, or anyone who wants to showcase their design skills of what their business does.

\*Only the gallery items are complimentary. Booth items can be rented for an additional fee.





# GALLERY OF CAKES

Show off your decorating skills in the cake gallery and display your favorite cake designs!

Today's Bride will supply high-top tables covered & skirted with company name signage. Only cakes are permitted in the gallery. Candy or dessert stations not applicable.

**ATTENDEES VOTE ON THEIR FAVORITE DESIGN!**

Voting is controlled by only one vote per attendee.



**SPACE IS RESERVED ON A FIRST-COME, FIRST-SERVE BASIS**  
**DEADLINE TO RESERVE: JANUARY 15, 2025**

# PORTRAIT GALLERY

Photographers have the opportunity to display their portraits at the show.

You will need to supply one easel per portrait (framed or unframed). Photos should be 16" x 20" or larger. Make sure your name is somewhere on the portrait or frame. Electric is an extra charge if needed.



# GOWN GALLERY

Bring mannequins to feature the latest fashions, styles, and dresses in the gown gallery.

Tell us how many you're bringing and Today's Bride will supply a sign with your company name on it.



**TO RESERVE SPACE IN THESE GALLERIES:**

Reserve your space: Contact Abby Crowder at  
Abby@TodaysBride.com or 330-670-9545 x12

**ANY QUESTIONS?**  
**CALL 330-670-9545 x12**



# EXHIBITOR SERVICES

## AMAZON FAVORITES & CUSTOM SIGNS

Check out our exhibitor favorite things on our amazon storefront: [pros.todaysbride.com/favorite-products/](https://pros.todaysbride.com/favorite-products/)

Items such as tables, tape, carts, & custom design signs/backdrops.

Availability and turnaround is dependent on scheduled production at time of order.

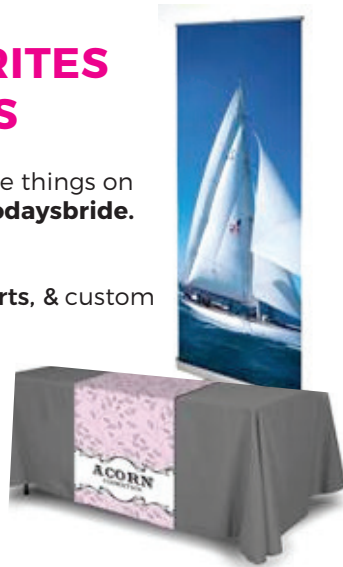

For more samples & ideas visit [pros.TodaysBride.com/favorite-products](https://pros.TodaysBride.com/favorite-products) or email [shows@todaysbride.com](mailto:shows@todaysbride.com)

## RENTALS

Miller's is the official decorator for the Today's Bride Wedding Show, offering discounted pricing on various rental items. The items will be placed in your booth space before the show unless you prefer to pick them up at their warehouse beforehand.



Call **330-753-9104**  
Angel, [amk@millersparty.com](mailto:amk@millersparty.com)  
with any questions and to place your order. Deadline to order is **January 15, 2025.**

## PRINT



Looking for help with design and print of show materials? Today's Bride can help you with business cards, brochures, postcards, & more!



**330-670-9545**

Availability and turnaround is dependent on scheduled production at time of order.



**RTH AV**

### AUDIO VISUAL RENTALS

Rock The House Entertainment is offering a special discount to all Today's Bride exhibitors on monitor rentals, truss, booth lighting, custom media creation, and more! **440-232-7625 // [rentals@rthgroup.com](mailto:rentals@rthgroup.com)**

## We appreciate you taking the time to review the Exhibitor Manual.

We are here to help you any way we can before, during and after the show. Don't hesitate to ask for our input on booth design ideas, marketing techniques and more. **330-670-9545 or 216-393-5677**

**Jennifer Judy x14**

[jennifer@todaysbride.com](mailto:jennifer@todaysbride.com)

**Jim Frericks x16**

[jim@todaysbride.com](mailto:jim@todaysbride.com)

**Denise Frericks x15**

[denise@todaysbride.com](mailto:denise@todaysbride.com)

**Abby Frericks Crowder x12**

[abby@todaysbride.com](mailto:abby@todaysbride.com)

**Kelsey O'Hearne Bohl x22**

[kelsey@todaysbride.com](mailto:kelsey@todaysbride.com)

**Phil Bell x23**

[phil@todaysbride.com](mailto:phil@todaysbride.com)