



Today's Bride[®]

WEDDING SHOW

EXHIBITOR MANUAL

SATURDAY & SUNDAY,

January 27 & 28
2024

I-X CENTER

ONE I-X CENTER DR.
CLEVELAND, OH

SATURDAY:
12PM-6PM

SUNDAY:
10AM-5PM

EXHIBITOR RESOURCES:
pros.TodaysBride.com/January

Today's Bride®

WEDDING SHOW

January 27 & 28, 2024 • I-X Center

Saturday 12pm-6pm

Sunday 10am-5pm

Show Day Exhibitor Help **Hotline**

440-482-1055

Need electricity? Trash overflowing?
Music too loud? Call or text to report
an issue without leaving your booth!

We are pleased to present the Exhibitor Manual for the I-X Center Show on January 27 & 28, 2024.

Inside this manual, you'll have a record of important deadline dates, general guidelines, exhibitor rules, important exhibitor documents, and added-value promotional opportunities.

This entire manual, online forms, and additional helpful resources to prepare you for the show are available online at:

[Pros.TodaysBride.com/January](https://pros.TodaysBride.com/January)

Please take the time to review the manual and website in its entirety, and share the information with your staff who will be setting up and/or working the show.

Thank you for being a part of the January Show! We are here to help you in any way we can before, during, and after the show. Don't hesitate to ask for our input on booth design ideas, marketing techniques, and more.

330-670-9545
or 216-393-5677

Jennifer Judy x14
jennifer@todaysbride.com

Jim Frericks x16
jim@todaysbride.com

Abby Frericks x12
abbyf@todaysbride.com

Kelsey O'Hearne Bohl x22
kelsey@todaysbride.com

Phil Bell x23
phil@todaysbride.com

Ashley Zifer x13
ashley@todaysbride.com

DEADLINES

FRIDAY, DECEMBER 15, 2023

Final Show Balance Due

FRIDAY, DECEMBER 15, 2023

Pink Bag "Stuff It" Program Materials Due

Deliver or ship 2,000 flat pieces to the Today's Bride Office
1930 N. Cleveland Massillon Rd Akron, OH 44333

Learn More: pros.TodaysBride.com/jan-add

MONDAY JANUARY 8, 2024

Last Day to Order Electric at Discounted Rate

(if not included in your booth package)

To Order Visit: ordering.edlen.com

FRIDAY, JANUARY 12, 2024

Return Credentials Form

Learn More: pros.TodaysBride.com/jan-cred

GUIDED TOUR OF I-X CENTER

WEDNESDAY, DECEMBER 13, 2023 - 1:00-2:00PM

RSVP if attending to jennifer@todaysbride.com

WEDNESDAY, JANUARY 17, 2024

Order Additional Booth Rental Items

Call Angel at Miller's Party Rental at 330-753-9104 or email

amk@millersparty.com to reserve. Rental fees apply.

Learn More: pros.TodaysBride.com/jan-add

WEDNESDAY, JANUARY 17, 2024

Reserve Space and Rentals for the Inspiration

Galleries (Tables, Gowns, Cakes, Photos)

To reserve space: Contact Abby at 330-670-9545 x12

or email abbyf@todaysbride.com

FRIDAY, JANUARY 19, 2024

Reserve Stage Show Commercial and

Big Screen Video Space

SHOW DAYS	Saturday, January 27 Fashion Shows	12pm – 6pm 1:30pm, 3:00pm & 4:30pm	Silent Opening: 11:30am, be ready!
	Happy Hour	6pm - 7pm	Networking Event at the I-X Yuengling Pavilion Bar Two complimentary drink tickets per company will be in your Exhibitor Packets at check-in.
	Sunday, January 28 Fashion Shows	10am – 5pm 12:30pm, 2:00pm & 3:30pm	Silent Opening: 9:45am, be ready!

MOVE-IN	Friday, January 26	9am – 4:30pm	Free Parking. Drive-in Passes permitted. (\$35 for one-way pass, \$50 for round trip pass)
	<p>On Friday only, you may use a paid drive-in pass purchased from the I-X Center where you will be permitted to drive into the facility to unload. Drive-In passes are only good for up to one hour to drive in, unload your vehicle, and remove your vehicle. Some vehicles may not be able to unload close to their booth depending on vehicle clearance on the show floor. Drive-In passes are permitted for any type of car, van, truck, or trailer without additional labor required. Visit pros.todaysbride.com/drivein to pre-pay for a drive-in pass, or you may purchase the pass on Friday during move-in at the I-X Center Customer Service window from 9:00am - 3:30pm.</p>		
	Saturday, January 27	8am – 11am	\$10 per vehicle all day. No Drive-Ins. Hand carry or dollies only.
	Sunday, January 28	9am	Paid Parking. No Drive-ins. Hand carry or dollies only.

IMPORTANT! NO UNLOADING is permitted through the main EAST ENTRANCE Lobby Doors.

YOU MAY USE YOUR OWN 2 OR 4-WHEEL DOLLY/CART TO UNLOAD/LOAD YOUR VEHICLE without purchasing labor. If you need labor assistance to UNLOAD/LOAD, schedule with Miller's Party Rental at 330-753-9104 or email amk@millersparty.com.

MOVE-OUT	Sunday, January 28	5pm – 8pm	No exhibits may be taken down until after 5pm.
-----------------	---------------------------	------------------	---

Drive-In Pass vehicles may start entering the building approximately 6:00pm.

Vehicles cannot drive onto the show floor until the limousines have exited & carpet is rolled.

The takedown, removal or repackaging of booth materials and/or displays during posted bridal show hours is strictly prohibited. Not only is this disrespectful to attendees and neighboring booths, but it poses a hazard while transporting said materials through the event facility. Early tear down will result in forfeiture of the lead list and a \$100 fine.

EXHIBITOR ENTRANCE Located at Door 35A. Look for the Exhibitor Entrance awning. (See map)

CHECK-IN Today's Bride will have a CHECK-IN Booth during move-in at Door 35A to pick up your Exhibitor Packets with your credentials during move-in hours.

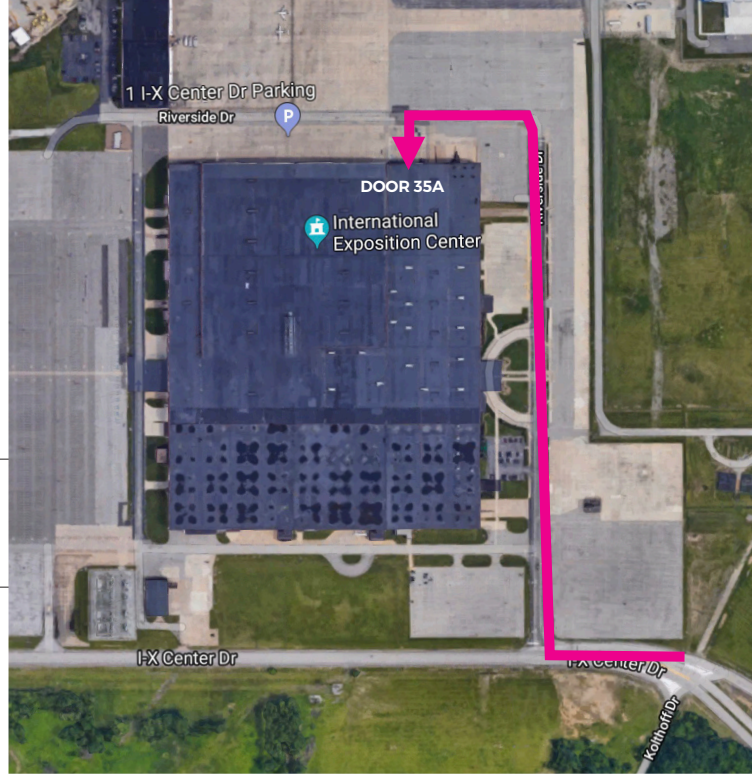

Today's Bride®

WEDDING SHOW

January 27 & 28, 2024 • I-X Center

Saturday 12pm-6pm

Sunday 10am-5pm

Show Day
Exhibitor Help **Hotline**

440-482-1055

Need electricity? Trash overflowing?
Music too loud? Call or text to report
an issue without leaving your booth!

OHIO TRANSIENT TAX LICENSE

Retailers selling at the show are responsible for complying with all vendor-licensing requirements. To obtain additional information and/or apply for an Ohio Transient Vendor's License call 888-405-4089 or visit tax.ohio.gov

FOOD SAMPLE GUIDELINES

Selling food products is prohibited. All sampling requests are to be submitted Today's Bride before the show. Sampling is limited to a 2-oz. portion for food and a 4-oz. portion for a beverage. The items being sampled must be part of your business services. **No samples of any alcoholic beverages permitted.**

DELIVERIES

Deliveries from common carriers (UPS, FedEx, 3rd parties, etc) will incur drayage charges for receipt of their delivery, storage, delivery to booth, and then return to docks to send out after the event. Call Miller's Party Rental Center at 330-745-9104 to discuss arrangements & fees ahead of time.

CLEAN-UP

Each evening after set-up and when the show closes, you can put trash in the aisles and the I-X Center cleaners will remove and empty. Bring your own trash bags.

IDENTIFYING ATTENDEES

For easier identification, engaged attendees will be wearing a pink "I Said Yes!" Today's Bride sticker.



LUNCH OPTIONS

Outside food or drink is not permitted to be brought into the I-X Center. Concession areas will be available throughout the show with ample seating.

WI-FI SERVICE

I-X Center offers Internet Service for a fee through Smart City Networks. Please visit pros.todaysbride.com/ix-wifi for prices. See page 5 for more information.

ELECTRIC

If an exhibitor wants electric above what's included (or excluded) from your contract, you must order from Edlen directly at ordering.edlen.com. Order by January 8, 2024 to receive discounted rates.

ON-SITE WIRELESS SERVICES

I-X CENTER LOCAL EXHIBITOR

NEED WIRELESS CONNECTIVITY?

Smart City Networks offers on-site wireless services for both attendees and exhibitors. Our **Complimentary Internet** is offered free of charge and is available in all public spaces and meeting rooms. Our **Exhibitor Internet** is available facility-wide on a 5 GHz wireless network, at speeds of 3 Mbps up/down per device. Depending on where you are in the facility, you may see both SSIDs (network names), but only Exhibitor Internet is supported in all areas.

EXHIBITOR INTERNET

Exhibitor Internet is available throughout the facility. Each purchase is device specific.

1 day for \$49.95
3 days for \$149.85
5 days for \$249.75

HOW TO CONNECT TO EXHIBITOR INTERNET

1. Open Wi-Fi settings on your device and select "Exhibitor Internet".
2. First time users will be asked to create an account and select a purchase option.
3. Follow the on-screen instructions to get connected.

COMPLIMENTARY INTERNET

Complimentary Internet is a free service and is available for use in all public spaces and meeting rooms.

HOW TO CONNECT TO COMPLIMENTARY INTERNET

1. Open Wi-Fi settings on your device and select "Free Internet".
2. First time users will be asked to create an account and verify their email address to get connected.

For questions regarding on-site wireless services, please call Smart City Networks at 216-265-7104. To order any other services we provide, please visit us online at: orders.smartcitynetworks.com.



BOOTH REGULATIONS

INCLUDED WITH SINGLE BOOTHS & LARGER:

- 8' high BLACK back pipe & drape
- 3' high side rails to separate your booth from neighbors
- 6' rectangle table covered in standard BLACK linen
- 2 chairs, if needed
- Company Name Placement Sign
- Nametags for Staff

*Tabletop booth includes covered 4' table with black linen and 1 chair.

Below are the booth design regulation guidelines. For a SINGLE BOOTH, plan within a 9' x 9' due to vertical poles & bases taking up an extra foot.

1. Displays taller than 8' must get approval from Today's Bride 30 days prior to the show. The backdrop must be tastefully finished on the back side. Property or displays taller than 4' must be placed into the rear half of the exhibit space.

2. Pipes or trusses placed at the front of the booth space are acceptable provided the sides of the space do not obstruct the neighboring booth, and provided there is a clear line of sight from both sides.

- Don't position retractable banners at the front of your booth space. Move halfway back or towards the back.

- The front five feet of your exhibit may not exceed FOUR FEET in height, unless it's a see-through structure.

3. Stay within the space confines of your booth. Exhibitors are prohibited from standing in the aisles or having their booth displays extend into the aisles.

4. If you plan to uplight your booth backdrop, you must bring or rent your own pipe & drape backdrop to place in front of the drape that is shared with the exhibitor behind you. The light will show through the thin drape.

If you are concerned your exhibit is not within the above guidelines, contact the Today's Bride team at: 330-670-9545 or email shows@todaysbride.com. If your exhibit isn't within the guidelines, you may be asked to make changes during move-in.

Exterior of any part of display facing a booth must be finished or suitably decorated.

Signage may not read into neighboring booths.

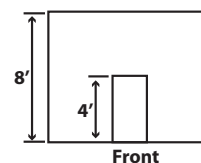
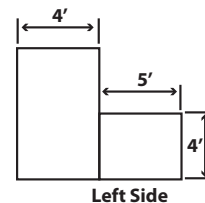
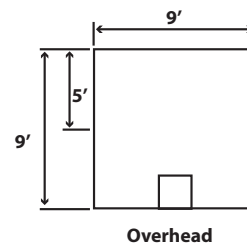
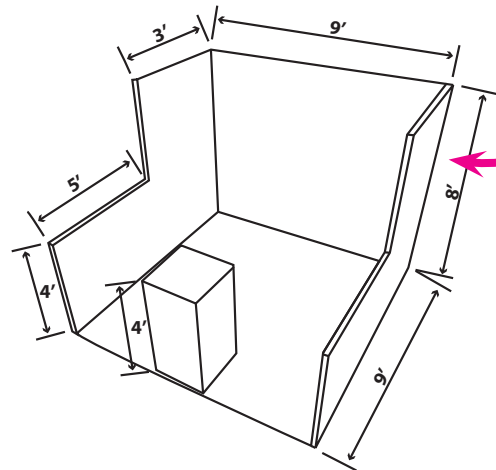

THE RULES & REGULATIONS

NOTE: It is your responsibility to understand and abide by these rules.

Our insurance carrier and facilities instructed us to strictly enforce the show rules and regulations as indicated on your show contract. This will ensure a safe and enjoyable trade show experience not only for participating businesses but, more importantly, our valued attendees. Please read and adjust your presentation and set-up display if necessary.

Review and share these guidelines with your staff scheduled to work your booth prior to the event.

1) Booth staff and all display materials **must stay within their contracted booth space** and not infringe upon the aisle walkways or other booth spaces. All aisles must remain clear of obstruction. Maximum backdrop height is 8' tall. The front 5' of your booth may not exceed 4' in height unless the structure is see-through. Backdrops taller must get approval from Today's Bride. Some booth locations are restricted.

2) **Maximum of four staff members** are permitted to exhibit in a single booth space at one time. **Maximum of two staff members** permitted at one time in a Table Top Space.

3) **NO distribution** of any marketing materials is permitted in the event facility, outside of contracted booth space. This includes, but is not limited to: exhibit hall aisles, registration areas, seating areas, rest rooms, parking lot/garage or other event facility grounds.

4) No helium balloons are allowed in the facilities. Lit candles are permitted if they are in tall hurricanes, placed toward the back of the booth, and you bring a Fire 10# ABC extinguisher.

5) **Distribution of any non-participating, non-contracted business literature (business cards, brochures, signage, etc.) is strictly prohibited.** This includes, but is not limited to, photographs or displays with "courtesy of" acknowledgment of said businesses. The only exception is if the mentioned business is also an exhibitor at the current show.

6) Distributing literature or displaying signage regarding a **competing Bridal Show or Event** (whether at your facility or not) **is strictly prohibited** unless Today's Bride is a sponsor of the event.

7) **Exhibitors MAY NOT begin to take down their booth display prior to show close.** The take down, removal, or repackaging of booth materials and/or displays during posted bridal show hours is strictly prohibited. Any set-up and disassembly must take place prior to guests' arrival and after their exit. You will be held accountable for any injury that may occur as a result of your negligence, forfeit the show's lead list, risk approval to exhibit at future Today's Bride Shows, and be fined \$100. Additionally, guests pay admission for a show advertised with set hours of availability, and we must honor these hours.

8) **All food and liquids to be served as samples** must be approved by both the facility and Jadlyn Inc./Today's Bride at least two weeks before the show. Distribution of samples without prior approval is not permitted and may result in dismissal of exhibit space at the show. Sample sizes are restricted to 2oz or less for food, 3oz or less for liquids. Alcohol is strictly prohibited. If using heat for samples, exhibitor must bring a Fire 10# ABC extinguisher to keep at said booth.

9) **Any outside food or drink for staff consumption is not permitted to be brought into the event facility.** Concession areas are available to purchase snacks and food during meal times.

10) **Distribution of alcoholic beverages, in any form, to attendees is strictly prohibited.**

11) **All audio, video and/or gaming productions must be maintained at appropriate noise levels** so not to infringe on the peace and harmony of neighboring booths. Jadlyn Inc./Today's Bride reserves the right to determine and set the acceptable sound level. Exhibitor is responsible for compliance of all music licensing.

12) Your company/businesses **must provide its own surge-suppressant power strip and extension cord(s)** to use for your trade booth's electrical needs.

13) **The leads generated from this show are for the exclusive use of the exhibitors who made the investment to participate.** The lead lists are seeded. Today's Bride monitors what you are sending. It is a violation of your exhibitor agreement to sell, lend, reproduce, exchange, copy or share the lead list to any non-exhibiting business or non-sponsored show or event that isn't authorized for this list. If this information is used or threatened to be used in an unauthorized manner, Today's Bride shall be entitled to seek relief in any court of competent jurisdiction, including but not limited to injunctive relief, actual and punitive damages, reasonable attorney's fees, costs and any and all other expenses. It is also a violation to use the list or permit the list to be used to promote any other multi-business bridal- or wedding-related show or event, including Client's own participation within such an event, and that damages to Today's Bride for each such use shall be no less than \$3,000.00. (A "use" shall mean each letter, mailing or e-mail sent to an attendee on the lead list). Upon breach of this Contract for any reason, exhibitor's license to use such Lead List shall cease immediately.

14) Exhibitor shall make good any damage to the building or fixtures caused by exhibitor or any of exhibitors' agents or employees. Exhibitors are responsible for any loss of their equipment and/or display material, or personal belongings, resulting from accidental breakage, misplacement, theft, fire or natural disaster, including, but not limited to, damage occurring while Management staff is assisting an exhibitor. If exhibitor uses the services of Management staff, then exhibitor agrees that the staff member is a volunteer for the exhibitor for worker's compensation purposes.

15) The Exhibitor is responsible for insuring its exhibit, personnel, display, automobiles, trailers, and materials against any damage or loss resulting from theft, fire, accidents, or any other cause. The Exhibitor acknowledges and assumes all risks associated with the use of the exhibit space and its surroundings. The Exhibitor agrees not to make any claims, demands, or legal actions against Today's Bride/Jadlyn, Inc. the Show sponsors, or the facility hosting the Show for any loss, damage, or injury incurred by the Exhibitor, its officers, directors, agents, representatives, employees, or their respective property. Neither Today's Bride/Jadlyn, Inc. nor the facility will be liable for the loss or damage of equipment, products, goods, exhibits, or other materials owned, rented, or leased by the Exhibitor, regardless of the cause.

These and all existing regulations will be strictly enforced. Violation to regulations may result in the exclusion from future trade shows and/or forfeiture of trade show lead list.



PRE-SHOW PREP

10 weeks before the show:

- Download the Exhibitor Manual to prepare and track deadlines pros.TodaysBride.com/January
- Set Goals for the Show
 - Number of appointments
 - Testing a new product
 - Taking deposits
 - Signing contracts
- Plan your booth design
 - Layout • Decor • Flooring
 - Banners • Signage • Electric Access
- Order marketing materials: flyers, promo items, samples, show special to offer, literature for brides Pink "Stuff It" Bags (if contracted)

6-4 weeks before the show:

- Stuff-it Bag Materials delivered to Today's Bride by **December 15, 2023**
- Order any extra rentals from a decorator, rental company or venue
- Prepare a way to collect hot leads at the show (guest book, paper or electronic forms)
- Pre-promote your presence at the show: share on social media, website, emails, voicemail & more
- Post online banner images promoting your booth and/or show special. Banners are located on the Exhibitor Manual website: pros.TodaysBride.com/January

3 weeks before the show:

- Proof your online listing on TodaysBride.com
- Audit your design & branding on your website and social media

2 weeks before the show:

- Submit your Sign & Nametag Credentials Form by **January 12, 2024**
- Submit your Show Special to post on TodaysBride.com
- Create a packing list of what to bring to the show (see right)
- Schedule & train your staff on booth etiquette, rules, the sales process, and show specials
- Plan parking and lunch options for your staff
- Prepare lead collection forms and the follow-up process (timing of phone calls, emails, direct mail, show special deadlines)
- Review the Exhibitor List online to strategize your networking

POST-SHOW PREP

After the show:

- Follow up on your hot leads from the show immediately
- Download the registered attendee list once alerted that it's available
- Continue working the leads throughout the attendees' engagement
- Renew the next show date to keep your online listing active

PACKING LIST

- ♥ Electrical Cords & Surge Protector
- ♥ Mobile Device Chargers
- ♥ Sales Literature
- ♥ Business Cards
- ♥ Appointment Book
- ♥ Clipboards
- ♥ Booth Design Layout
- ♥ Dolly or Transporting Devices (Suitcase or Wagon)
- ♥ Masking Tape, Scotch Tape, Shipping Tape
- ♥ Scissors, Stapler, Safety Pins, Straight Pins
- ♥ Portable Vacuum/Steamer
- ♥ Pens, Sharpie Marker
- ♥ Trash Bags
- ♥ Aspirin, Band-Aids, Second Pair of Shoes
- ♥ Hand Sanitizer
- ♥ Lead Collection Forms (or laptop/tablet)
- ♥ Breath Mints
- ♥ Good Selling Plan & Attitude

PROMOTE YOUR SHOW SPECIAL

Capture attention
at the show with
a show special,
prize, or contest!

Let us know about your show
promotion and we'll help get the
word out by:

- Posting it on the show page on
TodaysBride.com.
- Several will be mentioned in
email blast promoting the show
and shared on social media



NEED INSPIRATION?

Some past successful ideas:

- ♥ Stop by XX booth to receive a \$50 gift card off the purchase of XX.
- ♥ The first 100 brides to visit us at XX booth will receive a voucher.
- ♥ Be a part of beauty demos all day at the XX Salon & Spa Booth. Attendees will be chosen out of the audience to participate.
- ♥ Get \$200 off of a package at booth XX for the first 10 brides that book from the show.
- ♥ XX will be offering 20% discount off any purchases at the show!

**EMAIL YOUR SPECIALS TO
ASHLEY@TODAYSBRIDE.COM**

OR SUBMIT IT WITH YOUR CREDENTIALS FORM:

PROS.TODAYSBRIDE.COM/JAN-CRED

PROMOTE YOUR SPECIAL ON SOCIAL MEDIA

and use **#TodaysBride** to start a trend!

Follow us on:     and tag us @todaysbride

MARKETING UPGRADES

PINK BAG "STUFF-IT PROGRAM" \$475 DEADLINE DECEMBER 15, 2023



Guarantee every couple goes home with your marketing literature, whether you talked to them or not, by having your literature pre-stuffed in every pink welcome bag. All you need to do is supply us with **2,000 flyers** by **December 15, 2023**.

Ship or drop flyers off at:

Today's Bride, 1930 N. Cleveland Massillon Rd. Akron, Ohio 44333
*must be an exhibitor to qualify for this discounted price.

- Payment must accompany flyers. • Limited availability for some categories (call for details).
- The flyers **CANNOT** contain names or phone numbers of non-show participating exhibitors.
- The flyers **CANNOT** advertise another bridal show (at your facility or elsewhere).
- The flyers **CANNOT** exceed 10 pages. No magazines allowed.
- All flyers must be a single piece item and FLAT (call for approval of anything else).

STAGE COMMERCIALS \$100/ad DEADLINE JANUARY 12, 2024

Promote your company's services to a captive audience awaiting our high-energy fashion shows! 10-second static ads will rotate throughout the day on a big-screen television situated next to the fashion show stage.

BIG SCREEN VIDEOS \$100/video DEADLINE JANUARY 12, 2024

Market to attendees by displaying your company's wedding video(s)! A big LED screen will be situated near the fashion show with rotating videos throughout show hours.



WEBSITE

TodaysBride.com is averaging 16,000+ visitors a month. Bride traffic increases 30% more before & after the shows.

VENDOR WEBSITE LINK
All exhibitors will receive a basic profile page. Add a link to your website for **\$100**

FEATURED EXHIBITOR AD
\$150 Rotating banner ad linked to your profile page.

To order a marketing upgrade, visit pros.TodaysBride.com/jan-add

BOOTH DESIGN AWARD



January 2023: WHITE BIRCH BARN



January 2023: SO BLOOM

Go “all out” designing your booth and be rewarded with a Booth Design Award!

Your booth will be judged for Best Booth Design based on the following:

- ♥ Visual Display
- ♥ Creativity
- ♥ Functionality
- ♥ Staffing
- ♥ Best Use of Space
- ♥ Improvement from Year to Year

Need additional booth items to improve your display?

Miller's Party Rental Center is the official decorator for the Today's Bride Wedding Show. They are offering discounted pricing on various rental items. Any items ordered will be placed in your booth space before the show unless you prefer to pick them up at their warehouse. Call 330-753-9104 with any questions and to place your order.

Deadline to order is January 17, 2024. Contact Angel at 330-745-9104 or amk@millersparty.com

DESIGN TIPS:

1. **Most Important:** Make sure your company name is prominent. High and legible from a distance.
2. **Consider adding lights** to spotlight your products. Exhibit halls have dim, indirect lighting. Lights will make a huge impact visually & your booth will stand out from a row of exhibits. (Bring your own extension cords and power strips!) Note: Please refer to our booth regulations regarding lighting on page 6.
3. **Ditch the chairs** and stand during the show. Always appear interested and ready to assist potential customers.
4. **Think UP!** Consider using vertical space in your booth. Invest in tall backdrops and banners up to 8' tall. Layer displays on a table. Rent high cocktail tables. Use barstools for your guests. You'll gain valuable square footage this way and the booth will be more appealing and functional.
5. **Rent a unique backdrop.**

Connect with couples before the show to increase your chances of being on their “must-see” list!

Spread the word!

Promote the wedding show to your followers for a chance to win one of these three prizes:

FIRST PLACE



Win a Booth

at the June 9, 2024 I-X Center Wedding Show (\$1,300 value)

SECOND PLACE



Win a Local Love Ad

Or credit towards a larger ad in the 2025 Today's Bride Magazine (\$625 value)

THIRD PLACE



Win an Email Blast

Sent by Today's Bride to 4,000+ brides (\$600 value)

START COLLECTING POINTS NOW!

Minimum 25 points to qualify for a prize. Contest ends January 28, 2024 at 5:00pm.

1 POINT	FOR EVERY SOCIAL MEDIA POST TO YOUR BUSINESS PAGE Post or share about being at the Today's Bride Wedding Show on your business social media accounts and tag @todaysbride to get points. A maximum of 3 points will be given for posts on the show day.
3 POINTS	FOR EACH BLOG POST THAT MENTIONS THE SHOW Send a link to points@TodaysBride.com .
3 POINTS	FOR MENTIONING THE SHOW IN YOUR EMAIL SIGNATURE OR VOICEMAIL Send an email to points@TodaysBride.com to let us know.
5 POINTS	FOR MENTIONING THE SHOW IN AN EMAIL BLAST Send an email blast to your prospect database inviting them to come and see you at the Today's Bride Wedding Show, and to contact you for free tickets. Add points@TodaysBride.com to your email list to receive credit.
10 POINTS	FOR ADDING THE “TODAY’S BRIDE PARTNER” BADGE & LINK TO YOUR WEBSITE. Download the 2024 badge at pros.todaysbride.com/badge and send a link to points@TodaysBride.com .
15 POINTS	FOR MENTIONING THE SHOW IN ANY OTHER TRADITIONAL ADVERTISING (radio, TV, direct mail, print, etc.) Send an email to points@TodaysBride.com to let us know.

Follow us on:



and tag us @todaysbride

(You must tag us to receive credit!)

*Must be on an official business account

Hashtag **#TodaysBride** to start a trend!

visit Pros.TodaysBride.com/promote
for more banners, logos, and examples of how to create a post and how to tag us.

GALLERY OF TABLES

With your expertise, couples can imagine their dream reception decor including table shapes, linens, centerpieces, chairs, china, and favors.

ATTENDEES VOTE ON THEIR FAVORITE DESIGN!
Voting is controlled by only one vote per attendee.

RESERVE YOUR SPACE TODAY!

SPACE IS RESERVED ON A
FIRST-COME, FIRST-SERVE BASIS

DEADLINE TO RESERVE: JANUARY 17, 2024

WHAT YOU NEED TO DO:

1. **Reserve your space:** Contact Abby Frericks at AbbyF@TodaysBride.com or 330-670-9545 x12.

2. **For your table:** It's a 10 x 10 space. You are responsible for bringing everything.

-OR-

Borrow items at no extra cost from the gallery sponsor, **Lasting Impressions Event Rental*** They offer tables, chairs, linens, flatware & more! Contact Veronica to place your order: 216-591-1177 or veronica@lirents.net

Deadline to order is **January 17, 2024**

GALLERY SPONSOR:



We encourage collaboration with other exhibitors and will list them on the table sign created by Today's Bride. Any contributing companies must be exhibitors in the show to receive credit. Non-exhibitors may contribute, but their company is not permitted to be promoted on the table or in your exhibit space.

These spaces are for inspiration only. No promotional materials or literature (this includes business cards and signs) will be allowed in the gallery.

*Only the gallery items are complementary. Booth items can be rented for an additional fee.



GALLERY OF CAKES

Show off your decorating skills in the cake gallery and display your favorite cake designs!

Today's Bride will supply high-top tables covered & skirted with company name signage. Only cakes are permitted in the gallery. Candy or dessert stations not applicable.

ATTENDEES VOTE ON THEIR FAVORITE DESIGN!

Voting is controlled by only one vote per attendee.

**SPACE IS RESERVED ON A FIRST-COME, FIRST-SERVE BASIS
DEADLINE TO RESERVE: JANUARY 17, 2024**



PORTRAIT GALLERY

Photographers have the opportunity to display their portraits at the show.

You will need to supply one easel per portrait (framed or unframed). Photos should be 16" x 20" or larger. Make sure your name is somewhere on the portrait or frame. Electric is an extra charge if needed.



GOWN GALLERY

Bring mannequins to feature the latest fashions, styles and dresses in the gown gallery.

Tell us how many you're bringing and Today's Bride will supply a sign with your company name on it.



TO RESERVE SPACE IN THESE GALLERIES:

Reserve your space: Contact Abby Frericks at
AbbyF@TodaysBride.com or 330-670-9545 x12

ANY QUESTIONS?

CALL ABBY AT 330-670-9545 x12



EXHIBITOR SERVICES

AMAZON FAVORITES & SIGNS

Check out our Exhibitor Favorite Things on our amazon storefront: [Pros.todaysbride.com/favorite-products/](https://pros.todaysbride.com/favorite-products/)

Items such as tables, tape, carts, & custom design signs/backdrops.

Availability and turnaround is dependent on scheduled production at time of order.



For more samples & ideas visit pros.TodaysBride.com/favorite-products or email shows@todaysbride.com

RENTALS

Miller's is the official decorator for the Today's Bride Wedding Show, offering discounted pricing on various rental items. The items will be placed in your booth space before the show unless you prefer to pick them up at their warehouse beforehand.



Call **330-753-9104**

Angel, amk@millersparty.com with any questions and to place your order. Deadline to order is **January 17, 2024.**



PRINT



Looking for help with design and print of show materials? Today's Bride can help you with business cards, brochures, postcards, & more!



330-670-9545

Availability and turnaround is dependent on scheduled production at time of order.



RTHAV

AUDIO VISUAL RENTALS

Rock The House Entertainment is offering a special discount to all Today's Bride exhibitors on monitor rentals, truss, booth lighting, custom media creation, and more! **440-232-7625 // rentals@rthgroup.com**

We appreciate you taking the time to review the Exhibitor Manual.

We are here to help you any way we can before, during and after the show. Don't hesitate to ask for our input on booth design ideas, marketing techniques and more. **330-670-9545 or 216-393-5677**

Jennifer Judy x14

jennifer@todaysbride.com

Jim Frericks x16

jim@todaysbride.com

Denise Frericks x15

denise@todaysbride.com

Abby Frericks x12

abbyF@todaysbride.com

Kelsey O'Hearne Bohl x22

kelsey@todaysbride.com

Phil Bell x23

phil@todaysbride.com

Ashley Zifer x13

ashley@todaysbride.com